

Datenschutz durch Technik IT-Verfahren zu Datenschutz und -sicherheit im Smart Grid

Prof. Dr.-Ing. Dr. h. c. mult. Paul J. Kühn
University of Stuttgart, Germany
<http://www.ikr.uni-stuttgart.de>
paul.j.kuehn@ikr.uni-stuttgart.de

Tagung Nutzerschutz im Energieinformationsnetz
Daten- und Verbraucherschutz in Smart Grids
Berlin, BMWi, 17.06.2010

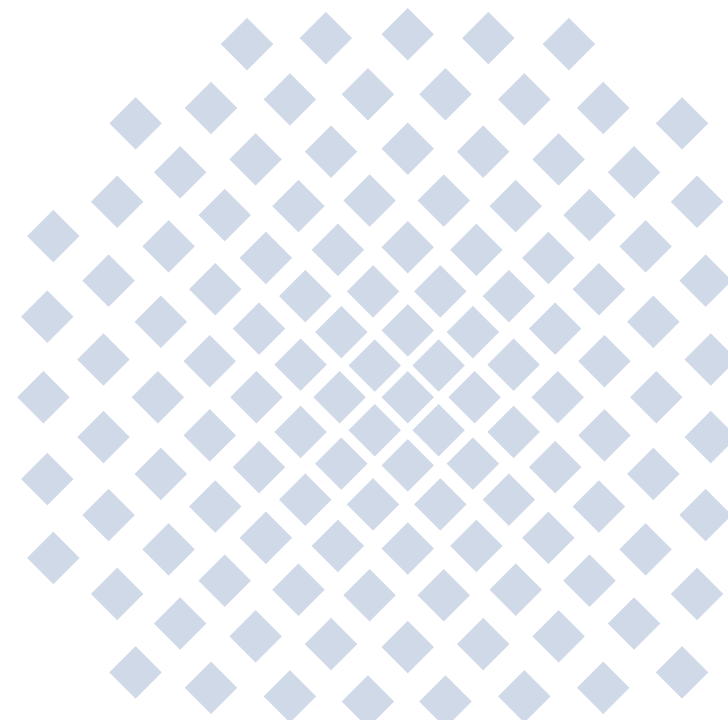

Moderation: P. J. Kühn, Universität Stuttgart

F. Rieger, CCC Chaos Computer Club e.V., Hamburg

J. Arnold, Hewlett-Packard, Böblingen

D. Hartge, Landesbeauftragte Datenschutz, Brandenburg

J. Jakobs, Freier Journalist, Lambsheim

O. Raabe, KIT, Karlsruhe
Elektromobilität und touristische Nutzung

A. J. Gaul, RWE Energy AG, Essen
Verträge und Datenströme beim Elektromobil-Roaming

A. Malina, IBM Deutschland GmbH, Mainz
Privates IP-Netz

Power Grid Szenario

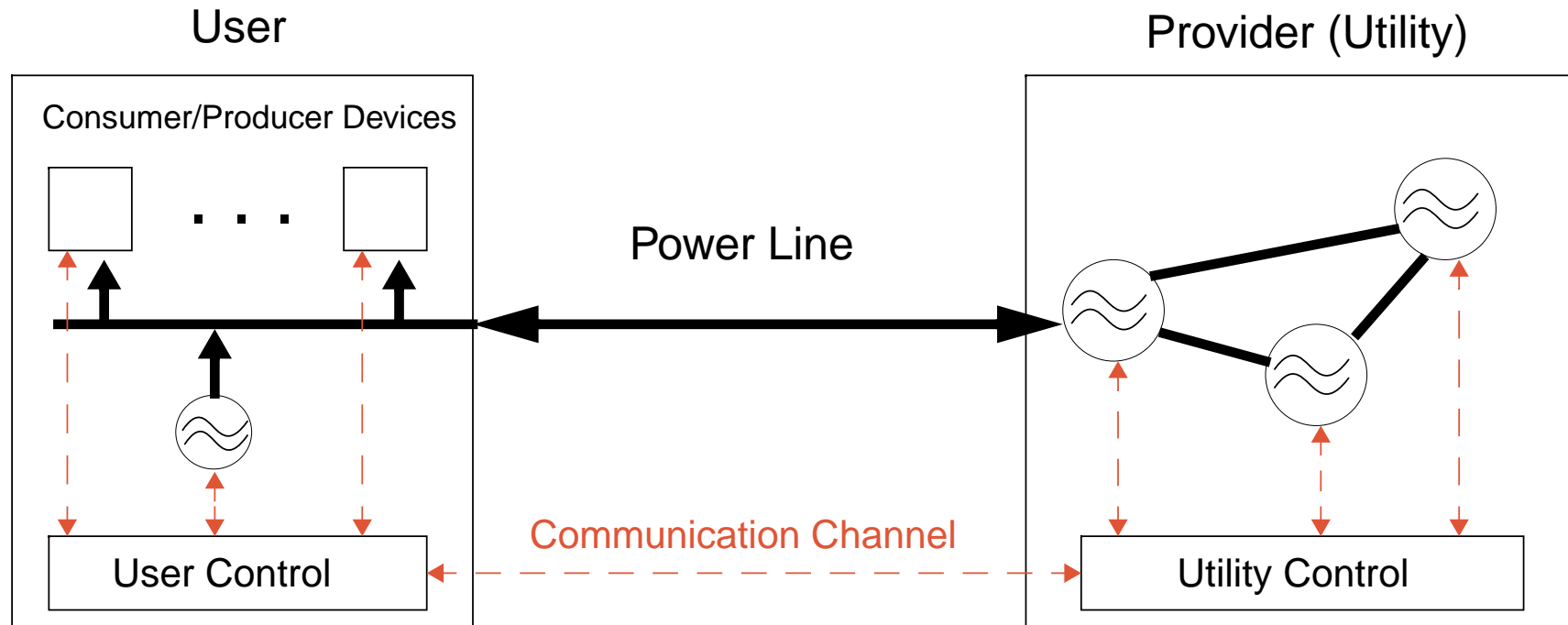

- Ideal Control**
 - Transparency of En. Consumption ---> Power Requirement $P(t)$
 - Transparency of En. Production ---> Power Availability (kW, Tariff, ...)
- Implementation**
 - Central Control (Provider)
 - Decentral Control (Consumer)
 - Distributed Control (Cooperation between Provider and Consumer)

Power Management Architecture

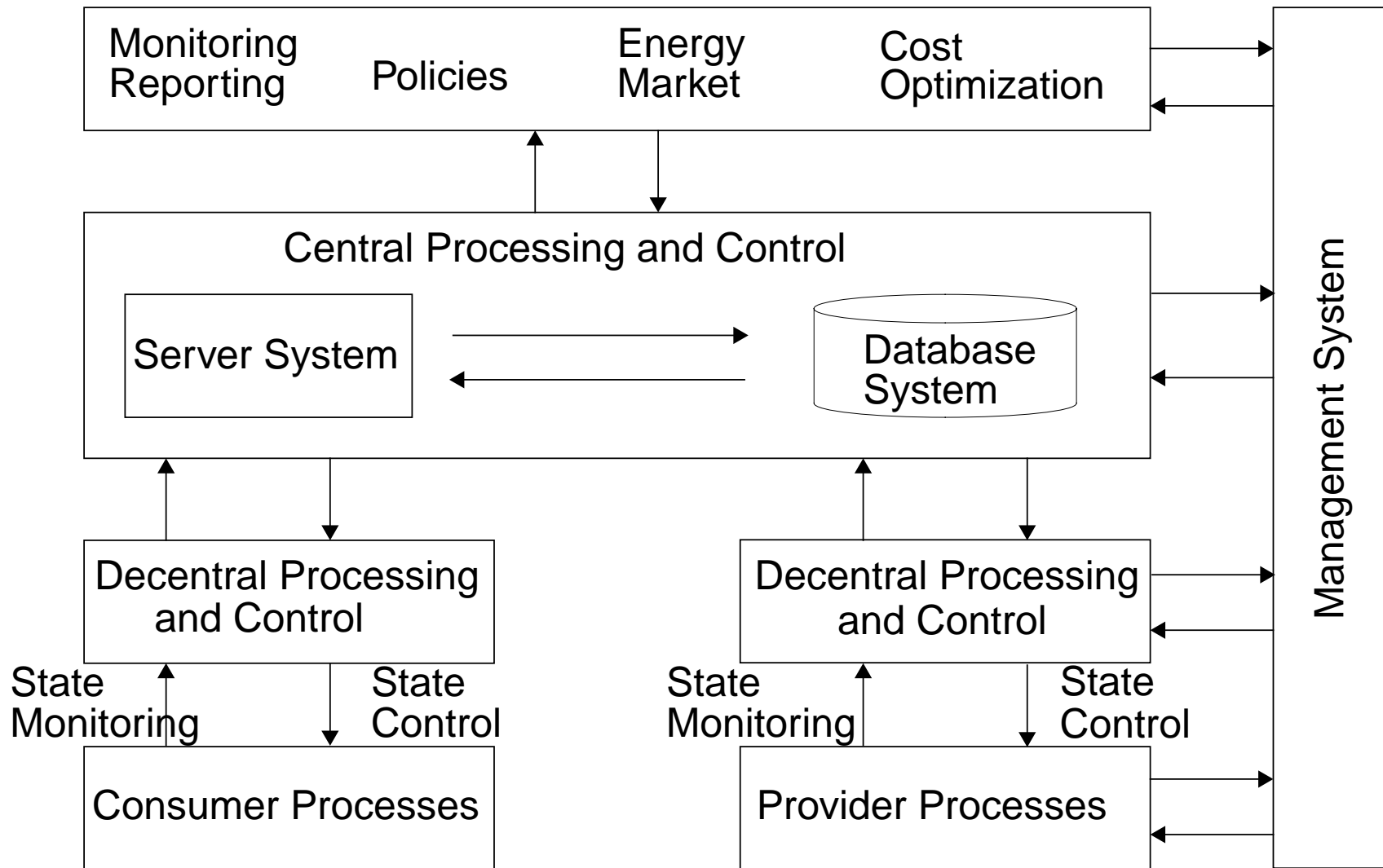

Privacy in the Smart Grid

- **Detailed User Power Consumption Data Underly OECD Privacy Principles**
 - Recording of Smart Meter Data \implies Conclusions on Personal/Company Activities
 - Storage Places and Durations of such Data?
 - Access Rights and Control of Usage of such Data?
 - Ownership of such Data?

- **Accuracy, Quality and Control**
 - Accuracy of Measurements or Future Needs
 - Granularity of Energy Consumption Data (Resolution)
 - Completeness and Relevance of Collected Data
 - Application Control (User or Provider?)

The Way Out of the Conflict

- **Need for Legal Framework**

- Documentation of Information Types of Collected Data
- Providing User Notification or User Access to Recorded User Data
- Limiting the Collected Data to the Required Minimum
- Limiting the Distribution of Private Consumer Data
- Limiting the Storage of User Data to the Absolutely Necessary Duration

- **Technical Solutions**

- Safeguarding of Personal Information Against Unauthorized Access, Disclosure or Copying
- De-Identifying : Anonymizing / Pseudonymizing of Identities
- Decentralized Control:
Smart Power Control Can be Done Completely Decentralized
Incentives: Online Information about Available Power and Time-Dependent Tariffs

Further Reading:

"Smart Grid Cyber Security - Strategy and Requirements"

Draft Report of the Smart Grid Interoperability Panel

Cyber Security Working Group

NIST (National Institute of Standards and Technology)

US Department of Commerce

Draft NISTIR 7628, February 2010 (305 Pages)

Technische Lösungsmethoden

- Zugriffsschutz und Identifikation (Passwortschutz)
- Abhörschutz (Verschlüsselung)
- Manipulationsschutz (digitale Signaturen)
- Authentisierung
- Angriffsschutz (Firewalls)

Herausforderungen

- Datensparsamkeit, Befristung der Speicherung
- Transparenz und Weitergabe aufgezeichneter Daten (Nachweis, Autorisierung)
- Verknüpfbarkeit von Beobachtungsmerkmalen
- Anonymisierung
- Vertrauenswürdige Instanzen und Reputationssysteme
- Aufteilung von Zuständigkeiten